

PANICKKER SWITCHGEAR

7E

VACUUM CIRCUIT BREAKER
UPTO 36KV

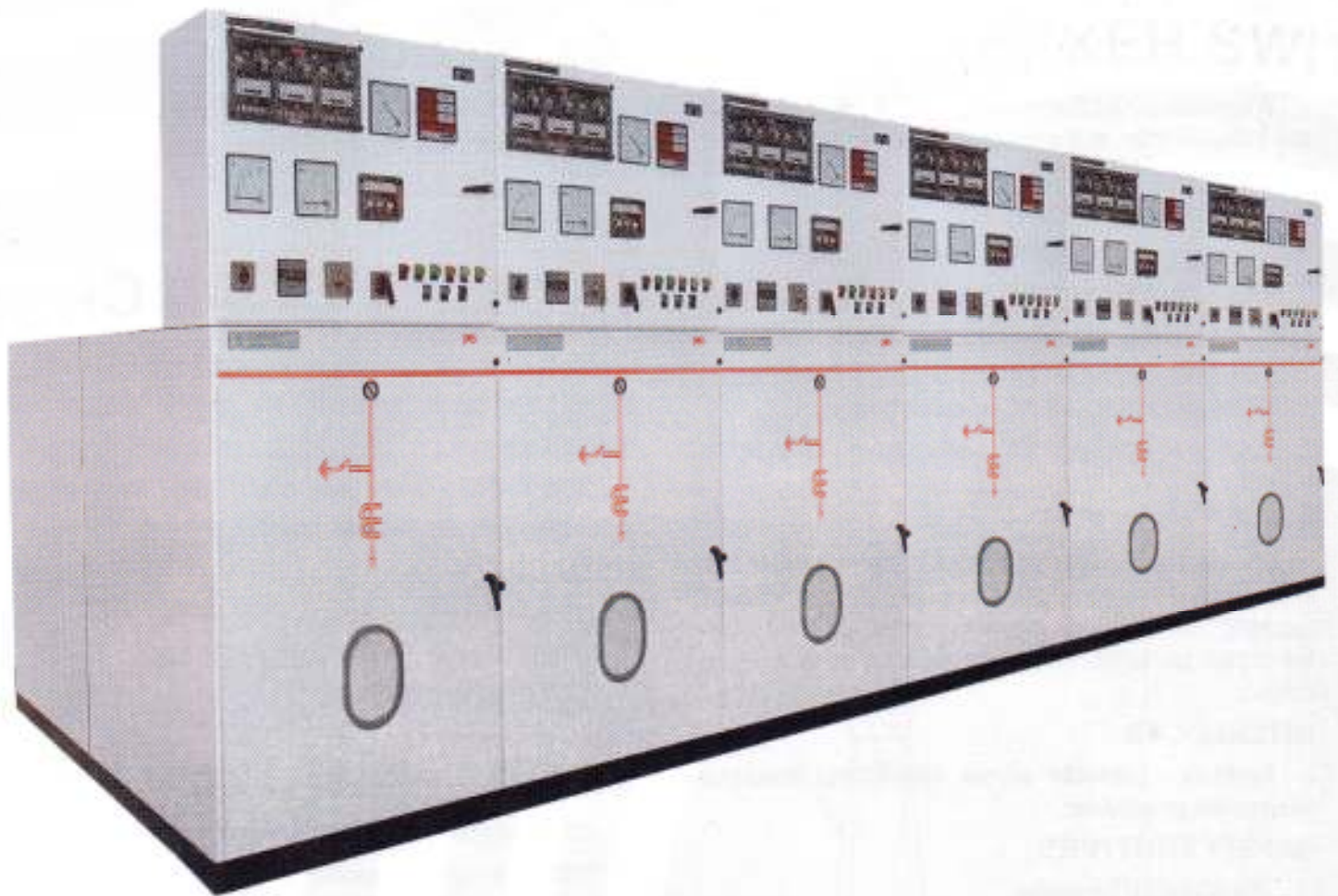

**PANICKKER
SWITCHGEAR**

ADDRESS:-

NH4, THANDALAM POST,
SRIPERUMBUDUR - 602105,
TAMIL NADU.

Email: sales@panickker.com

URL: <https://www.panickker.com>

DESIGN FEATURES HOUSING

The fixed housing of bolted construction is segregated into the main components

1. Busbars
2. CT Cable/Earth Switch
3. VCB / Secondary plugs / Main spouts and Shutters.

On the top of the housing is the relay / instrument chamber with a front hinged door for easy access. Control wiring can enter the top of this chamber, or through the bottom via a trough inside the VCB compartments.

CIRCUIT BREAKER - TRUCK

The Carriage is a sturdy welded steel construction. It houses the Vacuum Interrupters, main isolating contacts, independent spring charged mechanism, indicators, auxiliary switches, etc.

A removable front cover carries full operating instructions and indications for all mechanism/truck and VCB positions required by the operator.

VACUUM INTERRUPTERS

The interrupters are mounted in an epoxy resin housing.

The interrupters are operated by epoxy resin drive rods.

MECHANISM

Two types of mechanism are available. Motor wound spring charged and manual wound spring charged.

Local / remote electrical operations is available on request.

BUS BAR CHAMBER

The main spouts and connections to the bus bars are cast in epoxy resin as a three phase monoblock or single phase moulding. The conductor is of high conductivity hard drawn flat copper bar which also forms the main spout isolating contact.

INTERLOCKS

Necessary interlocks as per international standards requirement are provided.

SAFETY SHUTTERS

This is a part of the design.

SECONDARY PLUGS

It is provided with interlock through self-aligning contacts.

TESTS

Confirm to IEC 60056

Following type tests have been carried out

- | | |
|--------------------------|-------------------------|
| ■ Short time current | ■ Short circuit making |
| ■ Short circuit breaking | ■ Mechanical Endurances |
| ■ Low inductive current | ■ Capacitive current |
| ■ Temperature rise | ■ BIL |

SILENT FEATURES

HIGH BREAKING PERFORMANCE

Short make and break time makes it suitable for synchronising duty as well.

Arcing time is always less than half a cycle.

Low current chopping to avoid dangerous over voltages.
100 short circuit interrupting operations.

COMPACTNESS

Compact construction minimises the installation space

LESS MAINTENANCE

Since current is interrupted in a closed Vacuum chamber, the contact points never require any inspection for maintenance.

Since the life of the contacts is long, the Vacuum interrupter rarely require replacement.

RELIABILITY

Simple operating mechanism.

Unique Arc interruption characteristics.

well designed components.

HIGH SWITCHING LIFE

100 Short circuit interrupting operations

20000 Load current switching operations

30000 Mechanical Operations

TYPE DPVMD-DOUBLE BUS-BAR TYPE

VACUUM CIRCUIT BREAKERS

The type DPVMD double - busbar switchgear is a development of the type DPVMD single - busbar design. Almost all the standard features are retained.

Main and reserve busbars are selected by raising and lowering the circuit breaker. A raise / lower mechanism is built into the circuit breaker truck. This method of busbar selection is well proven and is therefore simple, and operation is error free.

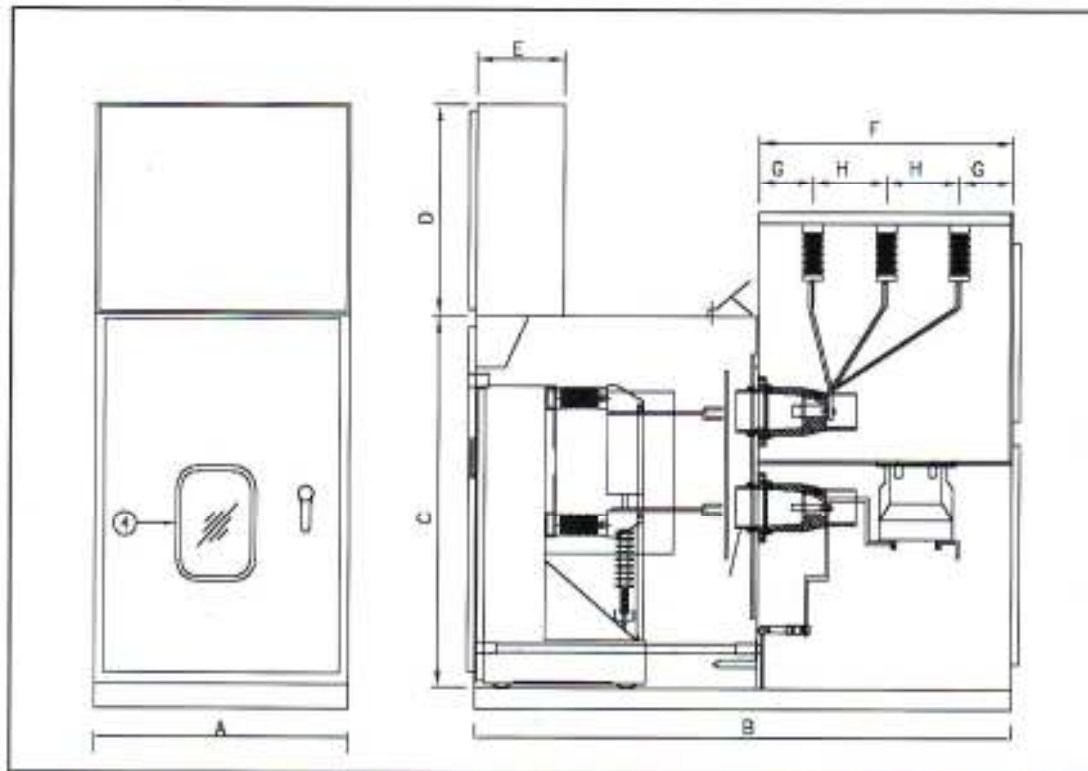

RATED VOLTAGE	A	B	C	D	E	F	G	H
12kV	750	1240	1300	700	350	720	160	210
24kV	1050	2000	1400	800	360	1040	220	300
36kV	1200	2560	1400	800	360	1400	300	400

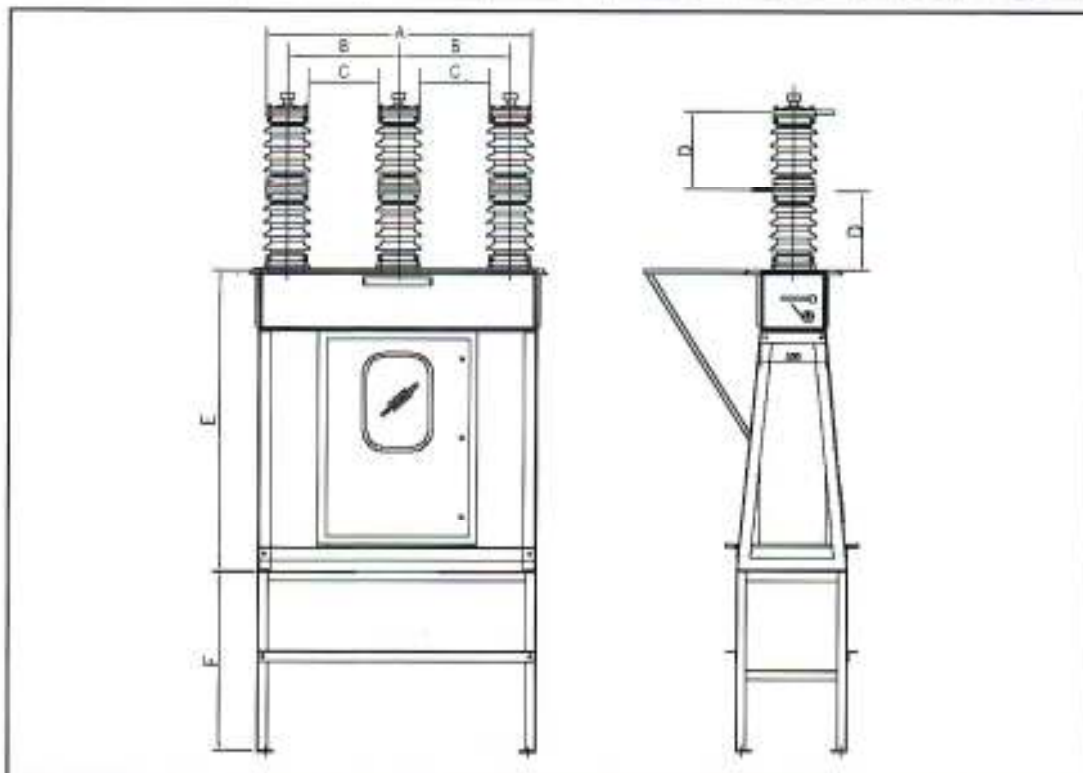

RATED VOLTAGE	A	B	C	D	E	F
12kV	1330	560	350	390	1500	1500
24/36kV	2075	860	650	500	1500	2000

All Dimensions are in mm

TECHNICAL DATA

TYPE	DPVM 6 DPVMD 6	DPVM 10 DPVMD 10	DPVM 15	DPVM 20	DPVM 30
Rated Voltage (kV)	7.2	12	17.5	24	36
Frequency (Hz)	50	50	50	50	50
Rated insulation level (1 min.) kVrms	20	28/36	36	50	70
1.2/50 micro sec. impulse (kV peak)	60	75/95	95	125	170
Rated Current A	630/1250/2000	1250/2000/3150	630/1250/2000	630/1250/2000	630/1250/2000
Rated short time current rating (3 Sec)	16/25/31.5	25/31.5/40	16/25/31.5	16/25/31.5	16/25/31.5
Rated short circuit breaking current (kA)	16/25/31.5	25/31.5/40	16/25/31.5	16/25/31.5	16/25/31.5
Rated short circuit making current (kA)	40/63/80	63/80/100	40/63/80	40/63/80	40/63/80
Operating duty	0-3 min-co-3 min-co 0-3 min-co-3 min-co		0-3 min-co-3 min-co 0-3 min-co-3 min-co		0-3 min-co-3 min-co 0-3 min-co-3 min-co
Operating time	< 70ms		< 70ms		< 70ms
Operating time	< 2 cycles		< 2 cycles		< 2 cycles
Operating time	< 70ms		< 70ms		< 70ms

As continuous development are made to all PANICKER products, equipment supplied may differ in detail from as described above

ADDRESS:-

**NH4, THANDALAM POST,
SRIPERUMBUDUR - 602105,
TAMIL NADU.**

Email: sales@panickker.com

URL: <https://www.panickker.com>

PANICKER SWITCHGEAR

VACUUM CIRCUIT BREAKER

UP TO 36 kV

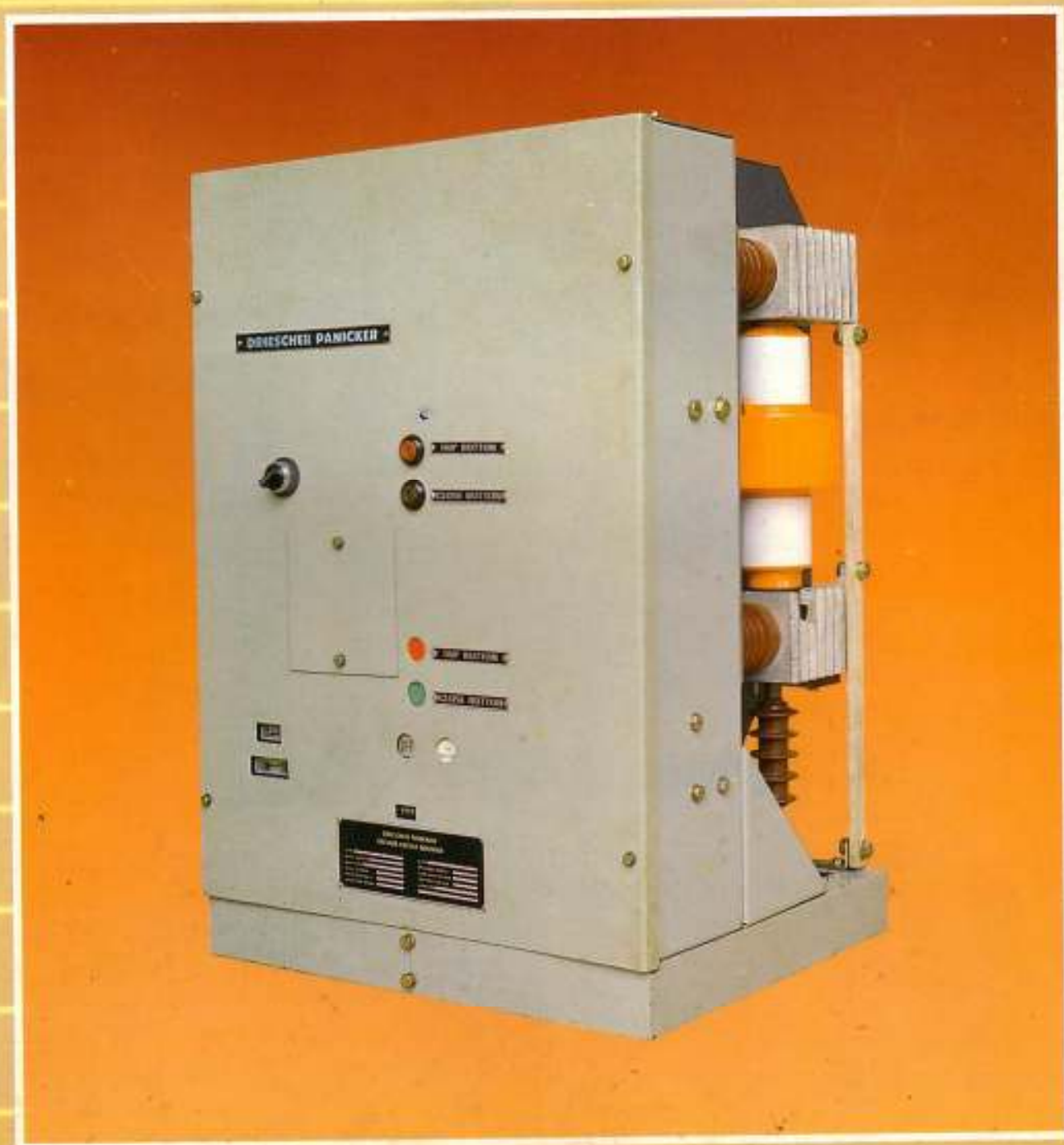

WHY VACUUM CIRCUIT BREAKER ?



Over last few decades, switchgear technology has undergone considerable advances by the utilisation of new arc extinguishing media such as air, oil, compressed air, SF₆ and finally vacuum. As in any technical development, the advent of a new technology does not mean that the existing ones are completely replaced. In some countries, bulk oil circuit breakers are still being manufactured in appreciable numbers. This is even more with minimum oil circuit breakers (MOCB). In fact, thousands of MOCBs are in service all over India since their introduction to Indian power distribution and utilisation network. However, one of the major constraints in use of these conventional oil circuit breakers for industrial applications is their limited switching life at normal and short circuit currents. In many of the industrial applications, the switching frequency can be more than 10 to 20 operations per day and in certain cases like furnace duty as high as 50 to 100 times a day. This aspect, combined with high degree of industrial pollution make the conventional breakers unsuitable for many of the applications. Therefore, the modern vacuum circuit breakers offer ideal solution to these switching applications because they meet almost all the requirements of industry.



SALIENT FEATURES :

High Switching Life :

- 100 Short circuit current interrupting Operations.
- 20000 Load current switching operations.
- 30000 mechanical operations.

High Operational Safety :

- Dead front structure, in which operating mechanism is arranged on the front side while the main circuit is mounted at the rear, ensures operating safety.
- The operating mechanism is enclosed in steel housing thus protected from dust and dirt.
- As no inflammable material is used there is no danger of accidental fire due to explosion.

LESS MAINTENANCE:

- Since current is interrupted in a closed Vacuum chamber, the contact points never require any inspection for maintenance.
- Since the life of the contacts is long, the Vacuum interrupter rarely require replacement.

High Breaking performance :

- Short make and break time makes it suitable for synchronising duty as well.
- Arcing time is always less than half a cycle.
- Low current chopping to avoid dangerous over voltages.

Low Noise :

- Operating noise is very low as the current is interrupted inside the Vacuum interrupter. Only operating noise is audible.

Reliability :

- Simple operating mechanism. Unique Arc interruption characteristics.
- Well designed components.

Immune to Pollution :

- Hermetically sealed interrupters ensures reliable and consistent Performance under polluted conditions.

Compactness :

- Compact construction minimises the installation space.

PRINCIPLE OF VACUUM INTERRUPTER

When the contacts separate, the current to be interrupted initiates a metal vapour arc discharge and flows through this plasma until the next current zero. The arc is then extinguished and the conductive metal vapour condenses on the metal surfaces within a matter of microseconds. As a result, the dielectric strength in the break builds up very rapidly.

The contacts are designed so that the self-generated field causes the arc root to travel. This prevents their local overheating when interrupting large currents.

The metal vapour arc discharge can only be maintained if a certain minimum current flows. A current that does not attain this level is chopped prior to current zero. This chopping current must be kept to a minimum in order to prevent unduly high overvoltages building up when inductive circuits are switched.

The use of a special contact material ensures that current chopping is limited to 4-5 A.

The rapid build-up of the dielectric strength in the break enables the arc to be safely extinguished even if contact separation occurs immediately prior to current zero. The maximum arcing time for the last-pole-to-clear is therefore only 15 ms.

The purpose of the arc-quenching device of a.c. breakers is to deionize the break immediately after current zero. For all conventional arc-quenching methods this means that the arc has to be cooled even before the contacts have reached the minimum quenching distance and before the next current zero, a fact which automatically increases the arc energy. The arc drawn in the vacuum breaker, on the other hand, is not cooled since the metal vapour plasma is highly conductive and the resulting arc voltage only attains values

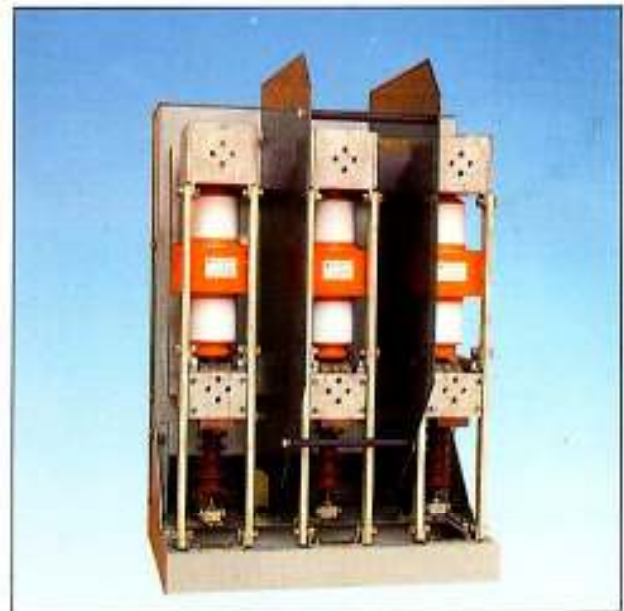

between 20 and 200 V. For this reason and because of the short arcing-times, the arc energy developed in the break is very small. This also accounts for the long electrical life of the vacuum breakers. For instance, they are capable of interrupting the rated short-circuit breaking current 100 times and the rated normal current 20000 times.

The contact clearance in the interrupter need only be 6 to 20 mm because under steady-state conditions a pressure of 10^{-9} bar suffices to obtain a high dielectric strength.

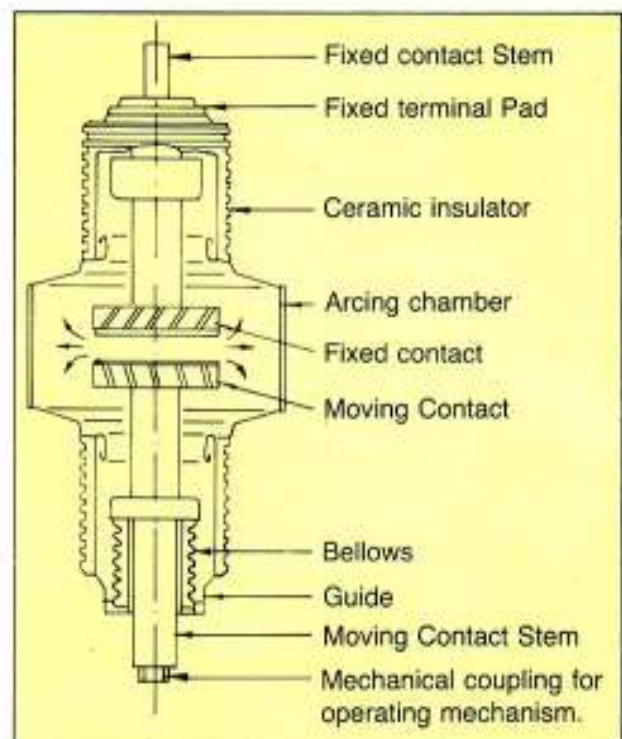

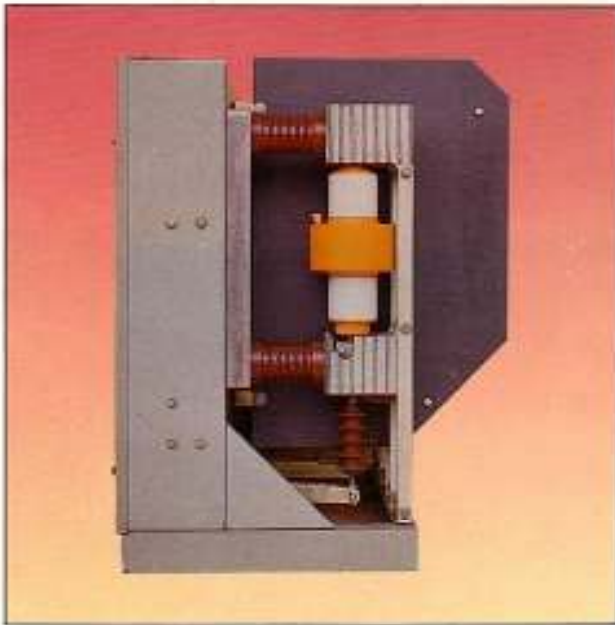

1. VACUUM INTERRUPTER
2. TERMINALS
3. FLEXIBLE CONNECTION
4. SUPPORT INSULATORS
5. OPERATING ROD
6. TIE BAR
7. COMMON OPERATING SHAFT
8. OPERATING CAM
9. LOCKING CAM
10. MAKING SPRING
11. BREAKING SPRING
12. LOADING SPRING
13. MAIN LINK

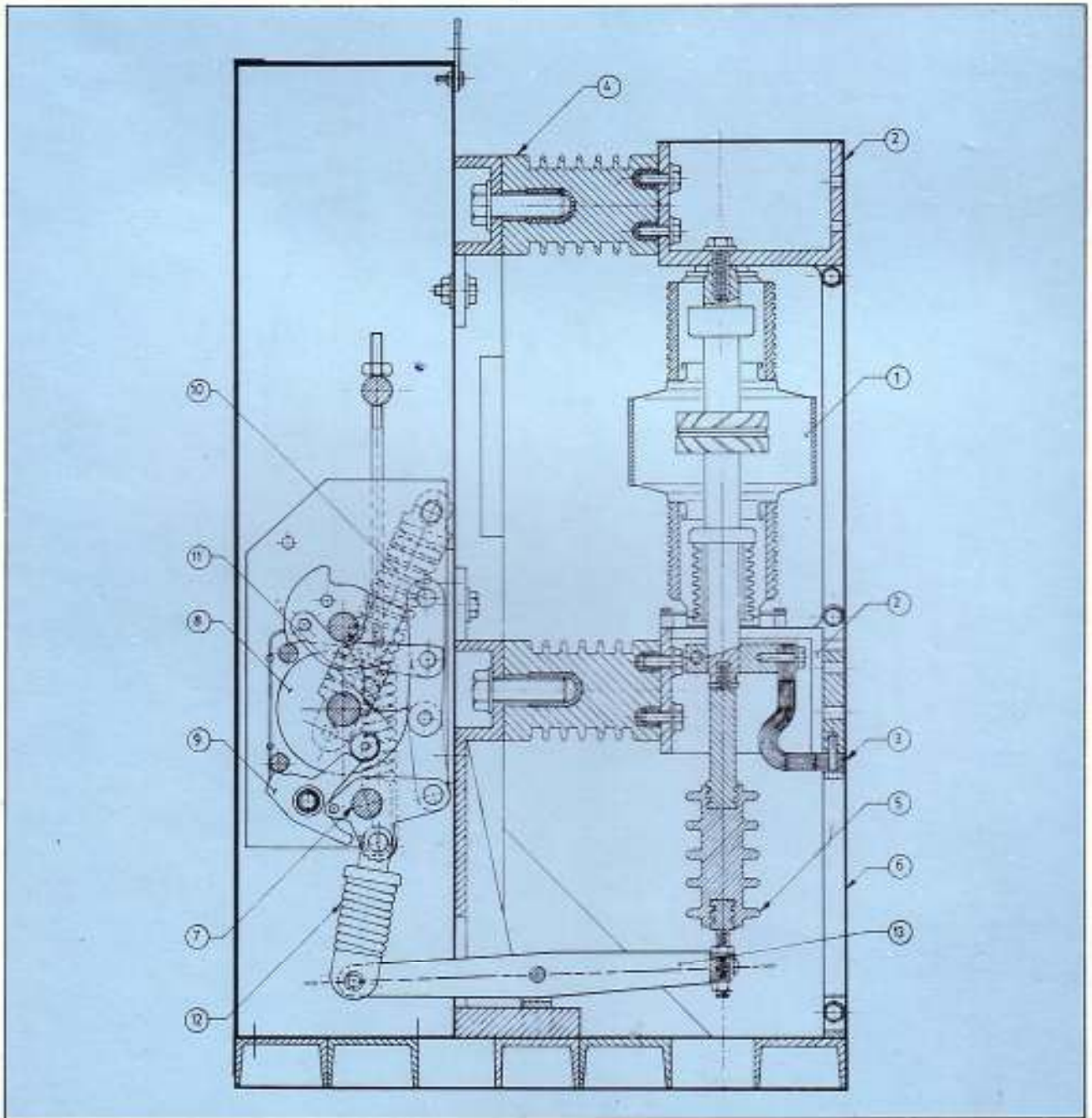

DESIGN FEATURES:

For Indoor and Outdoor application.

Both fixed and draw out types.

Compartmentalised design for safety.

Busbars of electrical grade copper, supported on strong epoxy insulators to withstand electromechanical stresses under short circuit conditions.

Easily accessible CT and cable chamber.

Provisions to couple the VCB Panel with loadbreak switch panels of our make, where applications demand switches for



isolation of loads and a breaker for controlling the switches. Both switch and VCB Panels can be coupled at site.

Interlocks applicable to various conditions for operation safety.

INTERLOCKING SYSTEM

		Withdrawn position	Isolated position	Test position	Intermediate position	Service position
Circuit breaker	Operatable	No	No	Yes	No	Yes
	Switching state	Open	Open	Open or Closed	Open	Open or Closed
Earthing switch	Operatable	Yes	Yes	No	No	No
	Switching state	Open or Closed	Open or Closed	Open	Open	Open
Control CKT connector	Connected	No	No	Yes	No	Yes

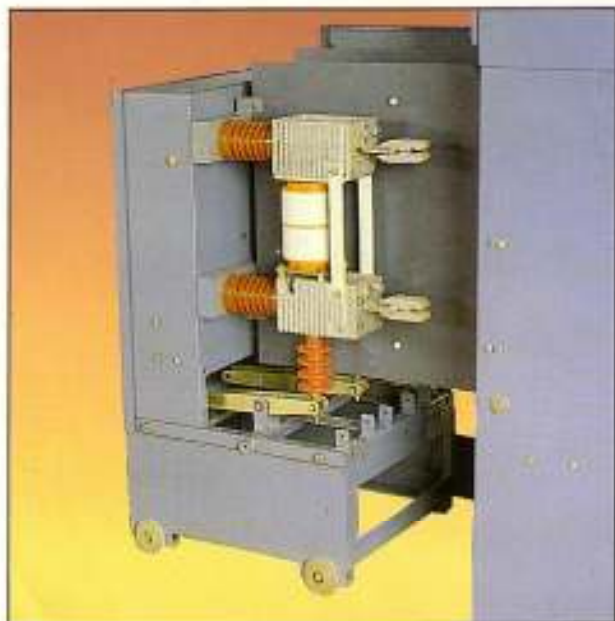

1. RELAY CHAMBER
2. BUSBAR CHAMBER
3. SUPPORT INSULATOR
4. METERING CHAMBER
5. DRAWOUT TYPE VCB
6. DRAWOUT TYPE P.T.
7. C.T.
8. CABLE CHAMBER
9. CLUSTER CONTACT
10. EARTHING SWITCH
11. SHUTTER

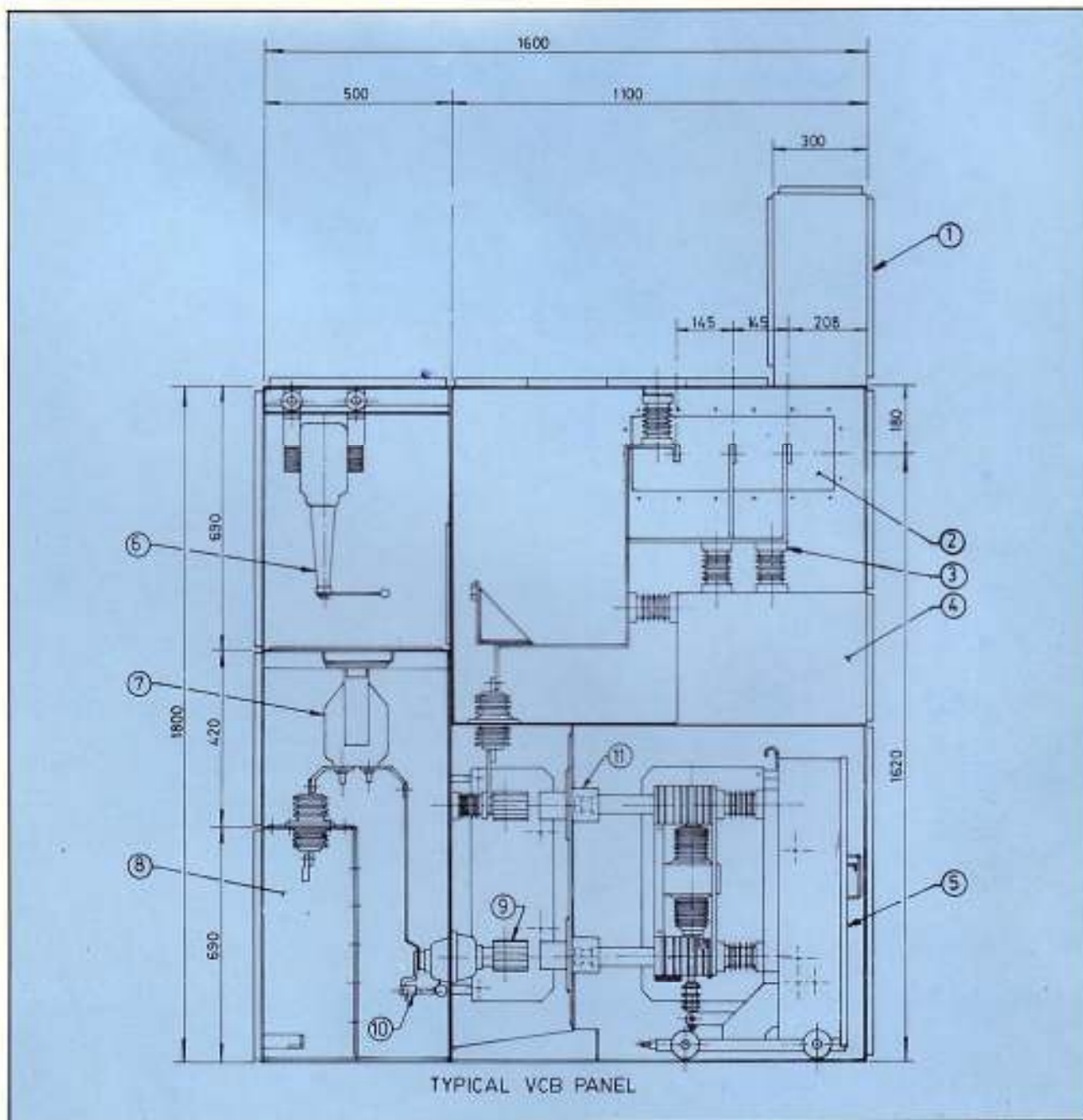

TESTS :

DRIESCHER PANICKER VCB s confirm to IEC 56 and IS 2516.

Following type tests have been carried out

- * Short time current
- * Short circuit making current
- * Short circuit breaking current
- * Mechanical Endurance
- * Low inductive current
- * Capacitive current
- * Temperature rise
- * BIL



TECHNICAL DATA

Type	DPSV 6	DPSV 10	DPSV 15	DPSV 20	DPSV 30
Rated Voltage	7.2	12	17.5	24	36
Frequency	50	50	50	50	50
Rated Insulation level 1 min. power frequency (KVRMS)	20	28	36	50	70
1.2/50 μ s impulse (kV Peak)	60	75	95	125	170
Rated Current (A)	630/1250/2000	1250/2000/3150	1250/2000	630/1250	1250/2000
Rated short time current rating (3 sec.) kA	16/25/31.5/40	25/31.5/40	25/31.5	25	20/25
Rated short circuit breaking current kA	16/25/31.5/40	25/31.5/40	25/31.5	25	20/25
Rated short circuit making current kA (Peak)	40/63/80/100	63/80/100	63/80	63	50/63
Operating duty	0- 3 min-co-3 min-co 0-.3 sec-co-3 min-co	0- 3 min-co-3 min-co 0-.3 sec-co-3 min-co		0- 3 min-co-3 min-co 0-.3 sec-co-3 min-co	
Opening time	25ms	25ms		25ms	
Interrupting time	< 2 Cycles	< 2 Cycles		< 2 Cycles	
No load closing time	35ms	35ms		35ms	

As efforts are made constantly to improve both designs and method of manufacture, equipment supplied may differ in details from the illustrations

PANICKER SWITCHGEAR

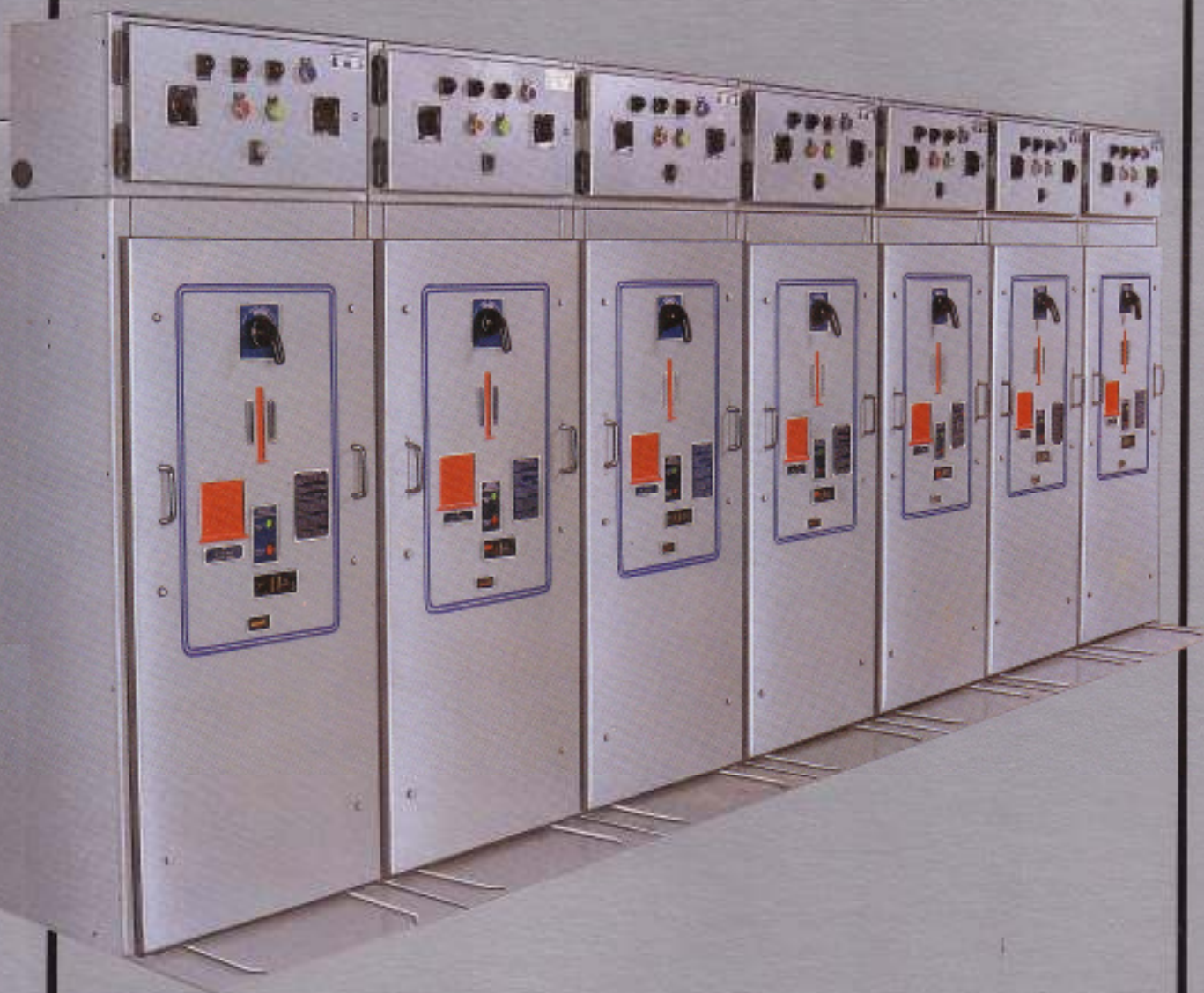

Vacuum Circuit Breaker Up to 36 kV



Fig. 1. View of the Truck



Fig. 2. External view of single busbar switchgear type DPVM
Standard blank instrument and relay panel is shown.

HISTORICAL BACKGROUND OF VACUUM CIRCUIT BREAKERS

Over last few decades, Switchgear technology has undergone considerable advances by the utilisation of new arc extinguishing media such as Air, Oil, Compressed Air, SF-6 and Vacuum. As in any technical development, the advent of new technology does not mean that the existing ones are completely replaced. In some countries, bulk oil circuit breakers are still being manufactured in appreciable numbers. This is even more with Minimum Oil Circuit Breakers (MOCB). However, one of the major constraints in use of these conventional oil circuit breakers for industrial applications is their limited switching life at normal and short circuit currents.

In many of the industrial applications, the switching frequency can be more than 10 to 20 operations per day and in certain cases like furnace duty as high as 50 to 100 times a day. This aspect combined with high degree of industrial pollution makes the conventional breakers unsuitable for many of the applications. Therefore, the modern Vacuum circuit breakers offer ideal solution to these switching applications because they meet almost all the requirements of the industry.

PRINCIPLES OF VACUUM CIRCUIT BREAKER

In a Vacuum circuit breaker, Vacuum interrupters are used for breaking and making load and fault currents. When the contacts in Vacuum interrupter separate, the current to be interrupted initiates a metal vapour arc discharge and flows through the plasma until the next current zero. The arc is then extinguished and the conductive metal vapour condenses on the metal surfaces within a matter of micro seconds. As a result the dielectric strength in the breaker builds up very rapidly. The properties of a Vacuum interrupter depends largely on the material and form of the contacts. Over the period of their development, various

types of contact materials have been used. At the moment it is accepted that a copper chrome alloys is the best material for High voltage circuit breaker. In this alloy, chrome is distributed through copper in the form of fine grains. This material combines, good arc extinguishing characteristic with a reduced tendency to contact welding and low chopping current when switching inductive current. The use of this special material is that current chopping is limited to 4 to 5 Amps.

At current under 10 KA, the vacuum arc burns as a diffuse discharge. At high values of current the arc changes to a constricted form with an anode spot. A constricted arc that remain on one spot for too long can thermally over stress the contacts to such a degree that the deionisation of the contact zone at current zero can no longer be guaranteed. To overcome this problem the arc route must be made to move over the contact surface. In order to achieve this the contacts are so shaped that the current flow through them results in a magnetic field being established which is at right angles to the arc axis.

This radial field causes the arc route to rotate rapidly around the contact, resulting in a uniform distribution of the heat over its surface. Contacts of this type are called radial magnetic field electrodes and they are used in the majority circuit breakers for HV applications.

A new design has come in Vacuum interruptor in which switchingover the arc from diffusion to constricted state by subjecting the arc to an axial magnetic field is made. Such a field can be provided by leading the arc current through a coil suitably arranged outside the vacuum chamber. Alternatively, the field can be provided by designing the contact to give the required current path. Such contacts are called axial magnetic field electrodes. This principle has advantage when the short circuit is in excess of 31.5 KA. Typical contact arrangement is shown in figure 3.

DESIGN FEATURES

HOUSING

The fixed housing is of bolted construction segregated into three main compartments.

- (1) Busbars
- (2) CT Cable/Earth switch
- (3) VCB/secondary plugs/main spouts and shutters.

On the top of the housing is the relay/instrument chamber with a front hinged door for easy access. Control wiring can enter the top of this chamber, or through the bottom via a trough inside the VCB compartments.

CIRCUIT BREAKER - TRUCK

The carriage is a sturdy welded steel construction.

It houses the Vacuum interrupters, main isolating contacts, secondary plugs, independent spring charged mechanism, indicators, auxiliary switches etc.

A removable front cover carries full operating instructions, and indications for all mechanism/truck and VCB positions required by the operator.

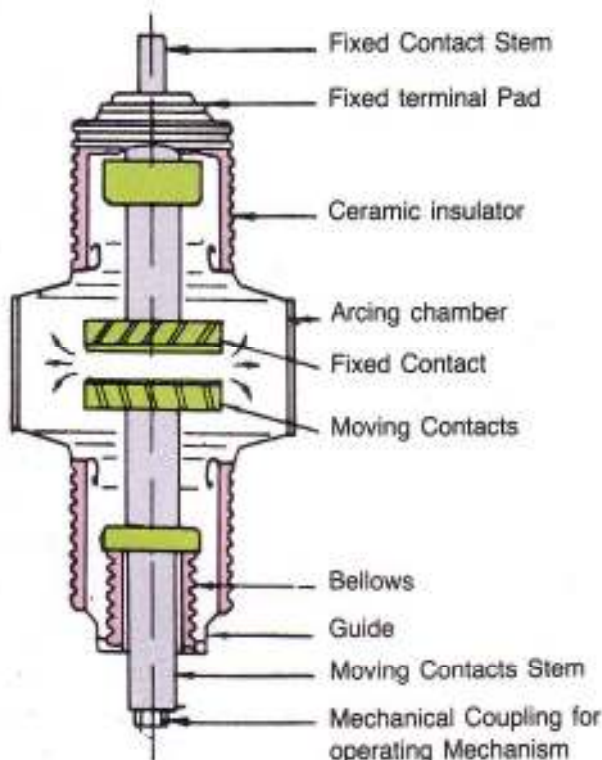

Fig. 3. Internal view of vacuum bottle.

VACUUM INTERRUPTERS

The interrupters are mounted in an epoxy resin housing. The interrupters are operated by epoxy resin drive rods.

MECHANISM

Two types of mechanisms are available. Motor wound spring and manual wound spring charged.

Local/remote electrical operation is available on request.

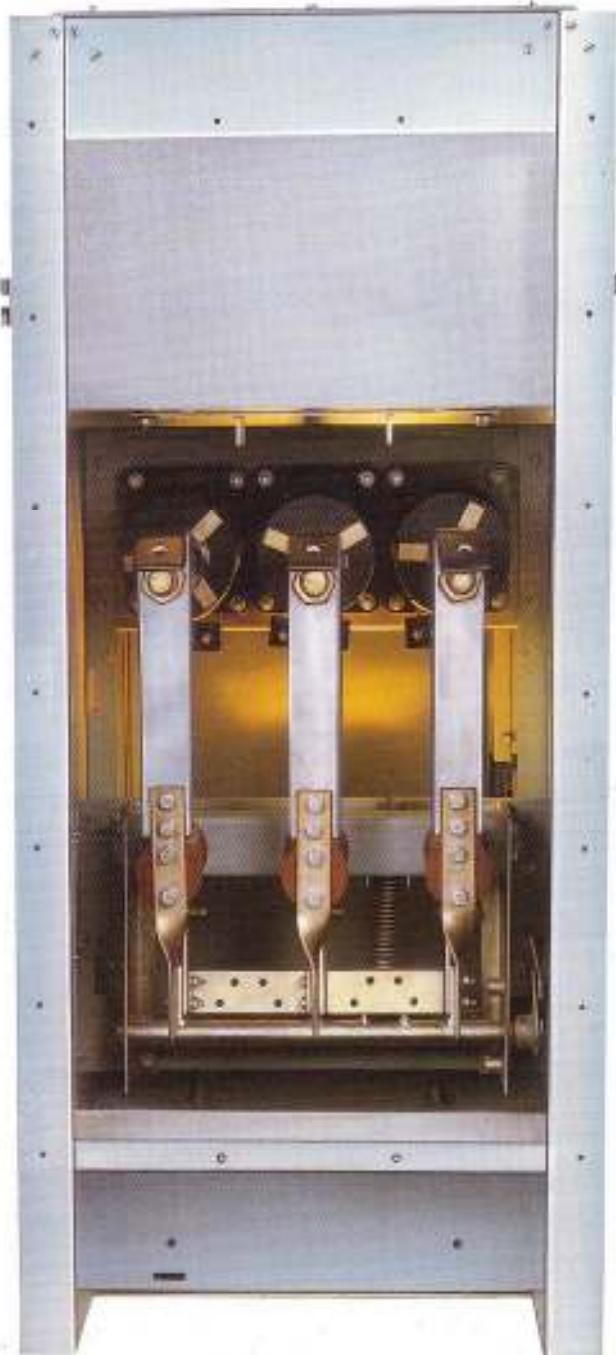

Fig. 4. Rear view of VCB.

BUS BAR CHAMBER

The main spouts and connections to the busbars are cast in epoxy resin as a three phase monoblock or single phase moulding. The conductor is a high conductivity hard drawn flat copper bar which also forms the main spout isolating contact.

The busbars are of unit length and are made of high conductivity hard drawn copper bar and are insulated with heat shrunk sleeving on epoxy resin coating and are fully insulated for the system voltage.

Access to the busbar compartment is through removable top plate which also acts as a pressure relief flap.

INTERLOCKS

For maximum operator's safety robust mechanical interlocks are provided to ensure that:

The circuit breaker cannot be closed unless the carriage locking mechanism or shoot-bolt is in the LOCKED position.

VCB cannot be engaged or withdrawn unless it is in the open position. VCB cannot be operated unless it is in the engaged or isolated position (not in between).

Earthing switch cannot be closed when the VCB is in the engaged position.

VCB cannot be inserted into the engaged position as long as the earthing switch is closed.

Other optional mechanical key interlocks (Castell locks) are provided on specific operational requirements.

SAFETY SHUTTERS

Automatic safety shutters cover the busbar and circuit spouts when the VCB is withdrawn or isolated. They can be padlocked in the closed position and either or both sets of shutters can be manually latched open for testing or maintenance purposes. The manual latch is automatically cancelled when the VCB is inserted into the compartment.

MAIN ISOLATING CONTACTS

The contacts are fitted to high conductivity hard drawn copper bars connected to the top of the interrupters for the busbar contacts and to the bottom of the interrupters for the cable contacts.

Highly self adjusting single contacts of adequate cross section are used and no hot spot is generated in the contact area.

The main spouts and connections of the cable terminations are cast in epoxy resin, which forms the primary for ring type CT's. The conductor is of high conductivity hard drawn copper and forms the main spout isolating contact.

SECONDARY PLUGS

Secondary wiring is carried from the mechanism with flexible cables in a bunch through secondary plugs to the instrument/relay chamber.

Thus all incoming supplies enter the instrument/relay chamber automatically when the truck is inserted.

EARTH SWITCH

Fully rated earth switch, interlocked with the VCB, separated from the front and fully lockable is fitted as optional equipment. The earth switch handle is removable.

VOLTAGE TRANSFORMER

PT to provide voltage signals for metering, protection and control is accommodated at the rear of the cubicle above the circuit compartment. The PT may be circuit or busbar connected, although circuit connection is more common.

Two options are available. Either fixed mounted PT or swing-out isolatable PT can be provided. PT is fused at both primary and secondary sides.

CABLE BOX

A separate detachable cable box can be provided if necessary.

Integral cable box can be supplied as standard.

Cabling arrangement are suitable for dry jointing on two connections.

SALIENT FEATURES

HIGH BREAKING PERFORMANCE

Short make and break time makes it suitable for synchronising duty as well.

Arcing time is always less than half a cycle.

Low current chopping to avoid dangerous over voltages.

100 short circuit current interrupting operations.

HIGH SWITCHING LIFE

100 short circuit current interrupting operations.

20000 Load current switching operations.

30000 mechanical operations.

HIGH OPERATIONAL SAFETY

Dead front structure, in which operating mechanism is arranged on the front side while the main circuit is mounted at the rear, ensures operating safety.

The operating mechanism is enclosed in steel housing thus protected from dust and dirt.

As no inflammable material is used there is no danger of accidental fire leading to explosion.

LESS MAINTENANCE

Since current is interrupted in a closed Vacuum

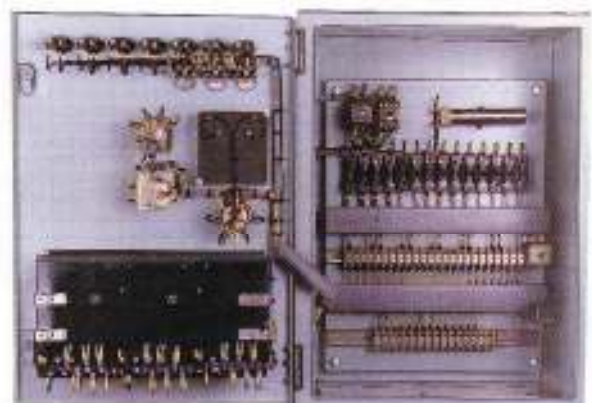

Fig. 5. Interior of instrument and relay chamber

chamber, the contact points never require any inspection for maintenance.

Since the life of the contacts is long the Vacuum interrupter rarely require replacement.

LOW NOISE

Operating noise is very low as the current is interrupted inside the Vacuum interrupter. Only operating noise is audible.

RELIABILITY

Simple operating mechanism.
 Unique Arc interruption Characteristics.
 Well designed components.

IMMUNE TO POLLUTION

Hermetically sealed interrupters ensures reliable and consistent performance under polluted conditions.

COMPACTNESS

Compact construction minimises the installation space.



Fig. 6. View of the porcelain clad VCB type PCVCB details on request.

TESTS

PANICKER VCBs

Conform to IEC 56

Following type tests have been carried out

- ★ Short time current ★ Short circuit making
- ★ Short circuit breaking ★ Mechanical Endurance
- ★ Low inductive current ★ Capacitive current
- ★ Temperature rise ★ BIL

TYPE DPVMD

DOUBLE - BUSBAR TYPE VACUUM CIRCUIT BREAKERS

The type DPVMD double-busbar switchgear is a development of the type DPVM single-busbar design. Almost all the standard features are retained.

Main and Reserve busbars are selected by raising and lowering the circuit breaker. A raise/lower mechanism is built into the circuit breaker truck. This method of busbar selection is well-proven and has the following advantages:

Simple, error-free operation.

Perfect interlock.

Minimum floor space (Same size as single busbar version).



Fig. 7. Assembly of double busbar switch gear type DPVMD.

**BREAKER IN
WITHDRAWN POSITION**

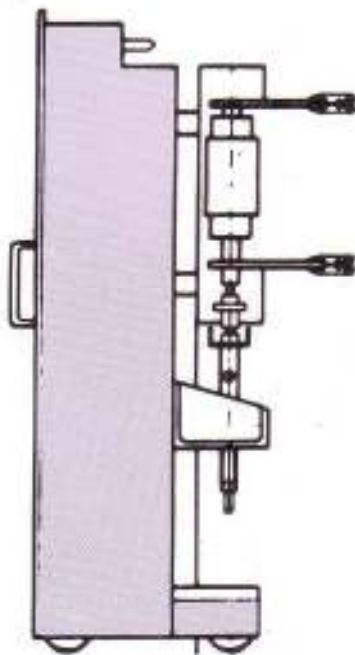

**R.H. SIDE VIEW
BREAKER IN TEST POSITION**

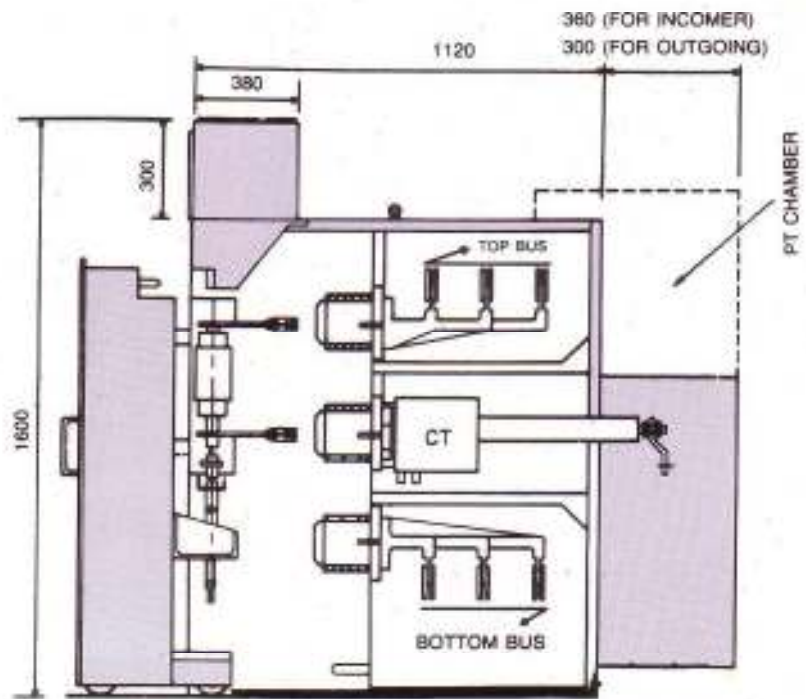

Fig. 8. Side View of double busbar arrangement.

**SECTIONAL SIDE VIEW
(BREAKER IN TEST POSITION)**

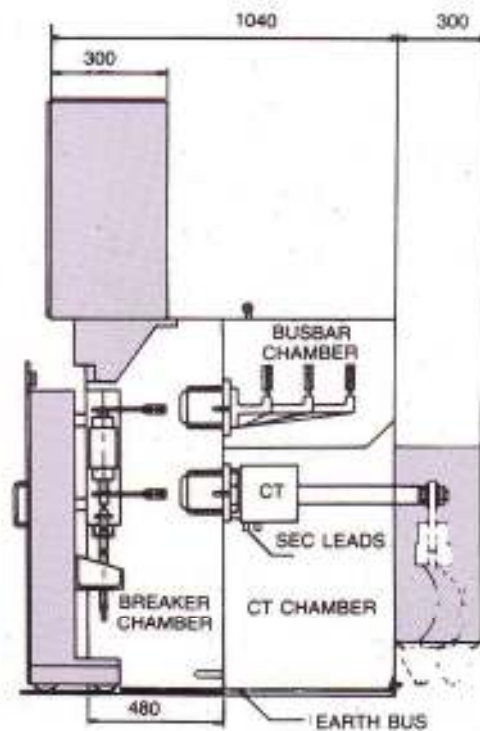
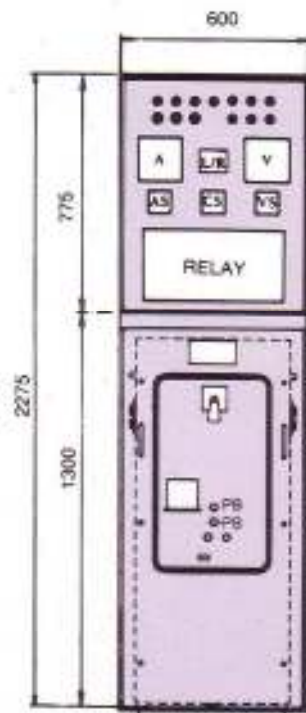

Fig. 9. View of typical single busbar arrangement.

TECHNICAL DATA

Type	DPVM 6 DPVMD 6	DPVM 10 DPVMD 10	DPSV 15	DPSV 20	DPSV 30
Rated Voltage	7.2	12	17.5	24	36
Frequency	50	50	50	50	50
Rated Insulation level 1 min. power frequency (KVRMS)	20	28/36	36	50	70
1.2/50 μ s impuse (kV Peak)	60	75/95	95	125	170
Rated Current (A)	630/1250/2000	1250/2000/3150	1250/2000	630/1250	1250/2000
Rated short time current rating (3 sec.) kA	16/25/31.5/40	25/31.5/40	25/31.5	25	20/25
Rated short circuit breaking current kA	16/25/31.5/40	25/31.5/40	25/31.5	25	20/25
Rated short circuit making current kA (Peak)	40/63/80/100	63/80/100	63/80	63	50/63
Operating duty	0-3 min-co-3 min-co 0-3 min-co-3 min-co 0-.3 sec-co-3 min-co 0-.3 sec-co-3 min-co		0-3 min-co-3 min-co 0-.3 sec-co-3 min-co		
Opening time	25ms	25ms	25ms		
Interrupting time	< 2 Cycles		< 2 Cycles		
No load closing time	35ms	35ms	35ms		

As efforts are made constantly to improve both designs and method of manufacture, equipment supplied may differ in details from the illustrations

PANICKER SWITCHGEAR

ADDRESS:-

NH4, THANDALAM POST,
SRIPERUMBUDUR - 602105,
TAMIL NADU.

Email: sales@panickker.com

URL: <https://www.panickker.com>